

MC-7380R Wireless PIR Intrusion Detector

1. Introduction

MC-7380R is an intrusion detector with energy accumulation processing and dynamic Metixing time chip. Its built-in Fresnel increases the energy receiving efficiency, and the sensitivity is high without false alarm, furthermore, it can distinguish which factor may cause false alarm.

Optional impulse insures it suitable for indoor with digital micro-processing. Advanced true motion recognition technology enables recognize the intruder from other interfering factors. Multi-mode and capability optional, which fit for various indoor environment and solve all kinds of interference, prevent false alarm and loss alarm.

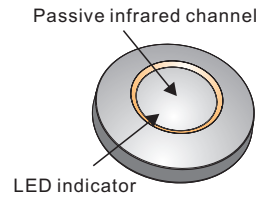

Figure 1. General View

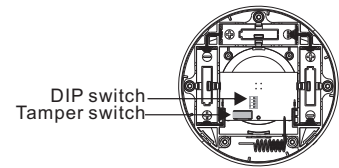
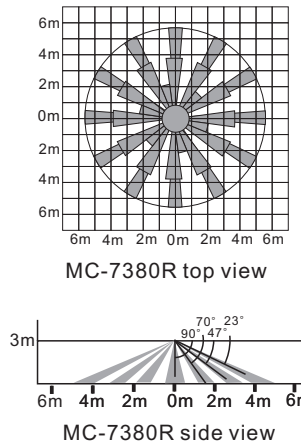

Figure 2. Inside View

2. Specification

- Model: MC-7380R
- Operating Voltage: 4.5V
- Quiescent Current: $\leq 25\mu A$
- Alarm maximum current: $\leq 15mA$
- Launch distance: $\leq 150m$ (in the open area)
- Launch frequency: 433/868MHz
- Detect the maximum radius: 5m/25°C
- Heartbeat report: send heartbeat report once at short intervals, interval time <3 hours
- Optical lens data
- Infrared area: 12+12+6+1
- Maximum coverage area: 10 * 10m (33 * 33 feet)
- Alarm indicator: Red LED lights up and goes out, then Blue LED lights.



MC-7380R top view

MC-7380R side view

Installation:

- Installation way: ceiling installation
- Installation height: 3 ~ 5m, between the back cover and the wall without angle

Environment

- Working temperature: -10°C to 50°C (14°F to 122°F)
- Storage temperature: -20°C to 60°C (-4°F to 140°F)
- Anti white (indoor): >9000lux
- Dimension: $\phi 111 * 40(H)$ mm

3. Installation

3.1 General Guidelines

The installation height is 3~5m

Don't face cold or heat directly

Don't face the sunshine directly

Don't install on an unstable base

Preventing pets over 20kg enter the detection area

3.2 Illustrated Installation Procedure

1. Disassemble unit:

A. Press the cover circum rotates it counter clock wise to open it

2. Mount base: 3 - 5m above ground

A. Secure the base to the mounting position with screws

B. Align the base triangle with the top cover

C. Hold the cover clockwise to tighten it

3.3 Change Battery

When the detector battery is weak, it will send out signal to the control panel, at the same time, you need to change battery for the detector. Draw the PCB board; follow the steps as below to change new battery. (as right picture).

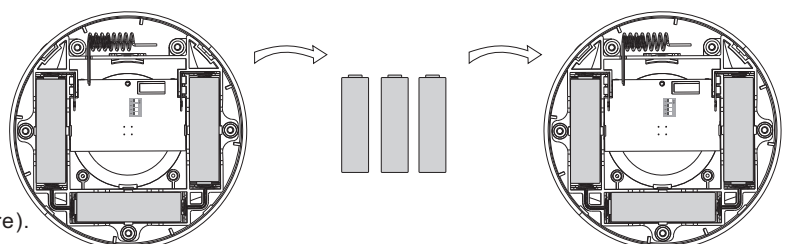

4. DIP switch function description

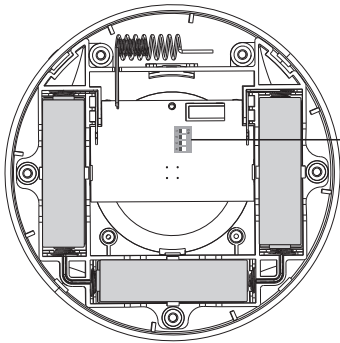

NO.	ON	OFF
4	Low sensitivity	High sensitivity
3	Alarm delay 5 minutes	Alarm without delay
2	LED Open	LED Close
1	Tamper invalid	Tamper effective

5. Perform walking test to the detection area

install the cover and close the fasten part Put the cover back, and circle the foundation clock wise till match well

1. Start the test at least 2 minutes after connecting power supply
2. Walking breadthwise at the remote and of the detection coverage , then will trigger the detector and the LED indications 2-3seconds
3. Testing in different direction to confirm the two boundaries of the coverage, ensure the detector is appoint to the central desired area.
4. From the detector 3-6 meters, slowly raise arm, and into the detection area, mark the lower boundary of passive infrared alarm. Repeat the above practice to determine its upper boundary.
5. the center of detection zone should not uphill incline. To obtain a good detection range , please adjust the vertical detection range, en-sure the detector is in a correct position.

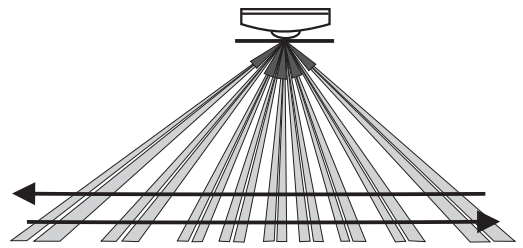
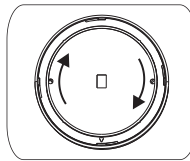

Note: Guide the user to perform a walk test at least once a week in order to ensure that each detector is in good condition.

6. Special Comments

Even the most sophisticated detectors can sometimes be defeated or may fail to warn due to :DC power failure/improper connection, malicious mask-ing of the lens,tampering with the optical system, decreased sensitivity in ambient temperatures near that of the human body and unexpected failure of a component part.The above list includes the most common reasons for failure recommended that the detector and the entire alarm system be checked weekly, to ensure proper performance.

An alarm system should not be regarded as a substitute for insurance. Home & property owners or renters sh-ouldbe prudent enough to continue insuring their lives & property, even though they are protected by an alarm system.

This device has been tested and found to comply with the limits for a Class B digital device, pursuant harmful interference in residential installations .This equipment generates,uses and can radiate radio frequency energy and ,if not installed and used in accordance with the instructions ,may cause harmful interference to radio and t-elevision reception. However, there is no guarantee that interference will not occur in a particular installation .If this device does cause such interference , which can be ver-fied by turning the device off and on ,the user is encouraged to eliminate the interference by one or more of the followingmeasures:

- Increase the distance between the device and the receiver.
- Connect the device to an outlet on a circuit different from the one that supplies power to the receiver.
- Consult the dealer or an expericned radio/TV technician.

WARNING! Changes or modifications to this unit not expressly approved by the party responsible for compliance could avoid the user s authority to operate the equipment